

# Steven Project – Detailed view (v1)

By Bill Weis

## *Steven – Progressive MS*

### Requirements:

1. Be able to voice control his Drive bed
2. Be able to voice control the lamp in his bedroom and living room
3. Be able to voice control two TVs/Amazon Prime, Sling TV

### Solution – High Level:

1. Designed a voice activated bed controller which gave Steven the ability to control all desired functions of his adjustable bed. He can control the bed using Alexa and Google
2. Installed two WeMo Smart Mini Switches so Steven can control both lamps
3. Installed two Amazon Fire TV Cubes so Steven can voice control his TV/entertainment.

## **Details of the Solution**

**1 – Voice Control his bed** – Steven has a Drive bed with a hard wired remote (15030HC-G). He wanted the 4 buttons (head up, head down, legs up, legs down) on the remote to be voice activated. With the Drive beds, motor current is passed through the hand held remote and it takes a combination of two switches to perform each function. This bed design is much more difficult to provide a backup (hand held remote) solution, so the approach we took is when the internet goes down, someone will need to replace the bed controller with the original handheld pendant. We have Drive bed customers with this same design approach who have successfully used our bed controllers for more than a year with no complaints, so the lack of being able to provide an alternative means of controlling the bed has not been a significant issue.

The voice activated bed controller uses mechanical relays with flyback diodes installed to protect the integrity of the relay contacts.

Steven's bed can be controlled by both an Amazon Echo and a Google Mini for added redundancy.

Here is a Visio diagram of the solution.

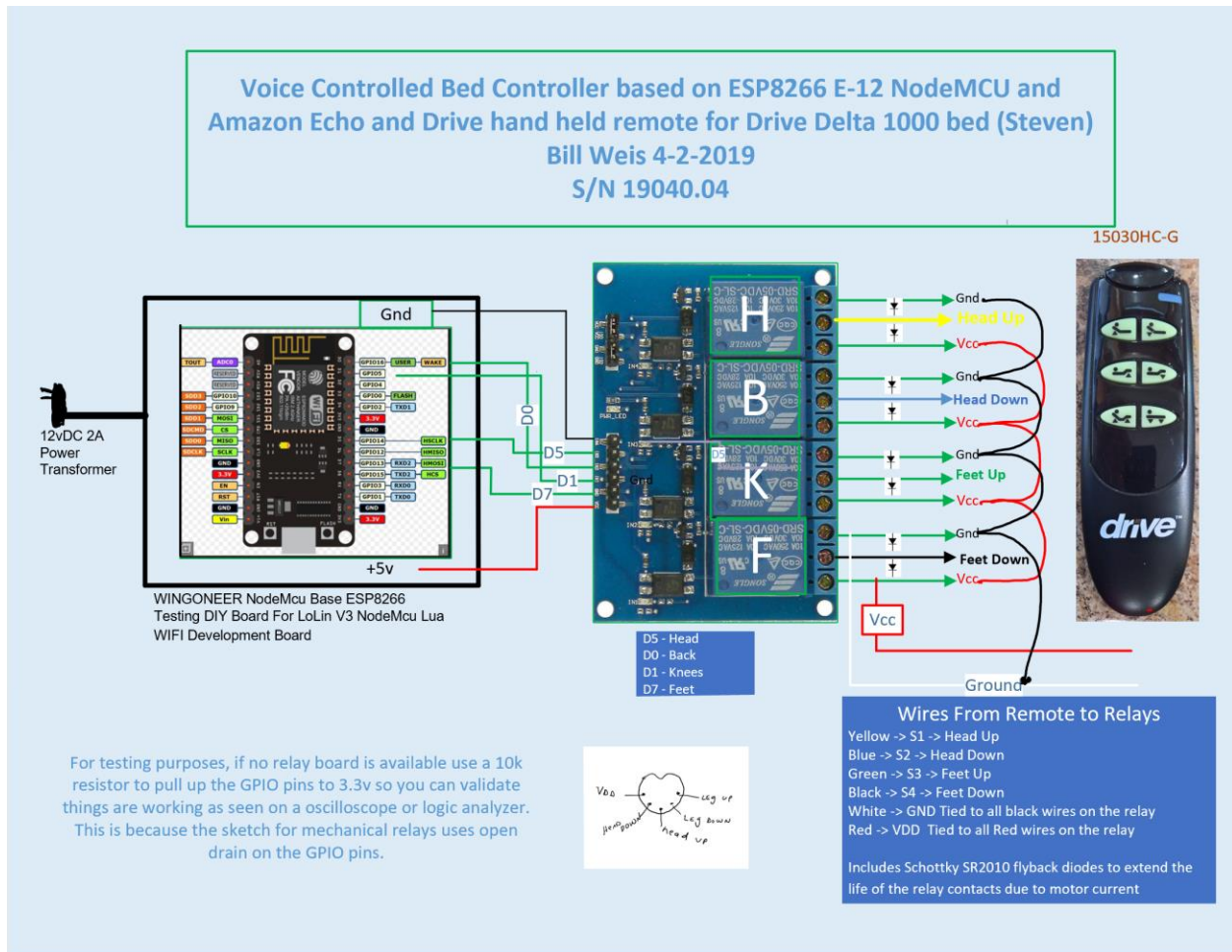

**3. Be able to voice control the lamp** – To give Steven the ability to use voice commands to control his bedroom and living room lamps we provided two WeMo Smart Mini switches.

**4. Doron wanted to be able to voice control the TVs in his bedroom and living room** – We provided and installed two Amazon Fire TV Cubes and configured it so Doron could voice control his TVs for Amazon Prime and Sling TV, etc.

## **Resources**

[Amazon Echo](#)

[Alexa Support](#) (Contact Support via the Amazon Alexa app - can have them call your number)

[Google Home getting started](#)

[Google Home Help Forum](#)

[Google Home Support](#) Phone number for Google Home hardware support = 855-971-9121 (24/7 days a week)

[Wemo Support](#) Phone number for Support = 1-844-745-wemo (9366)

inside the bed controller box. The drawing on the following page shows the voice activated bed controller, solid state relays and the remote.