

Milan Patel – Duchenne Muscular Dystrophy
Detailed view by Bill Weis

Requirements:

1. Be able to voice control his adjustable bed

Solution – High Level:

1. Designed a voice activated bed controller which gives Milan the ability to control the Head Up/Down and Foot Up/Down functions of his adjustable Invacare bed. We also provided the means for all 6 functions including Head Up, Head Down, Feet Up, Feet Down, Bed Up and Bed Down to be manually controlled. He can control the bed using Google and Alexa.

Details of the Solution

1 – Voice Control his bed – Milan has a full electric Invacare bed model 5301IVC which is controlled by a 1115290 pendant. This bed is a 6-function bed which includes Head Up, Head Down, Foot Up, Foot Down, Bed Up and Bed Down. For safety reasons, Bed Up and Bed Down require use of the 1115290 pendant which is functional through the use of the RJ50 connector that we added to our controller. Bed Lift and Bed Lower is a feature that is only used by a caregiver anyhow, and the caregiver can continue to perform Bed Lift and Bed Lower as they always have. All 6 functions are still controllable via the 1115290 pendant.

The voice commands can be issued through Alexa as well as through the Google Mini. The benefit of being able to voice control the bed via either smart speaker is redundancy as well as to be able to compare the performance of Alexa vs Google.

We provided Milan with the ability to move the head of the bed up/down for durations of 3,4,5 and 8 seconds. Routines were created on both Amazon and Google to make these voice commands customized for Milan's preference.

Here is a Visio diagram of the solution.

**Voice Controlled Bed Controller for Milan, mechanical relays to drive the
Invacare Full Electric 5301IVC bed, manual control for Lift and Lower
Bill Weis 2/14/2020
S/N 19047.09**

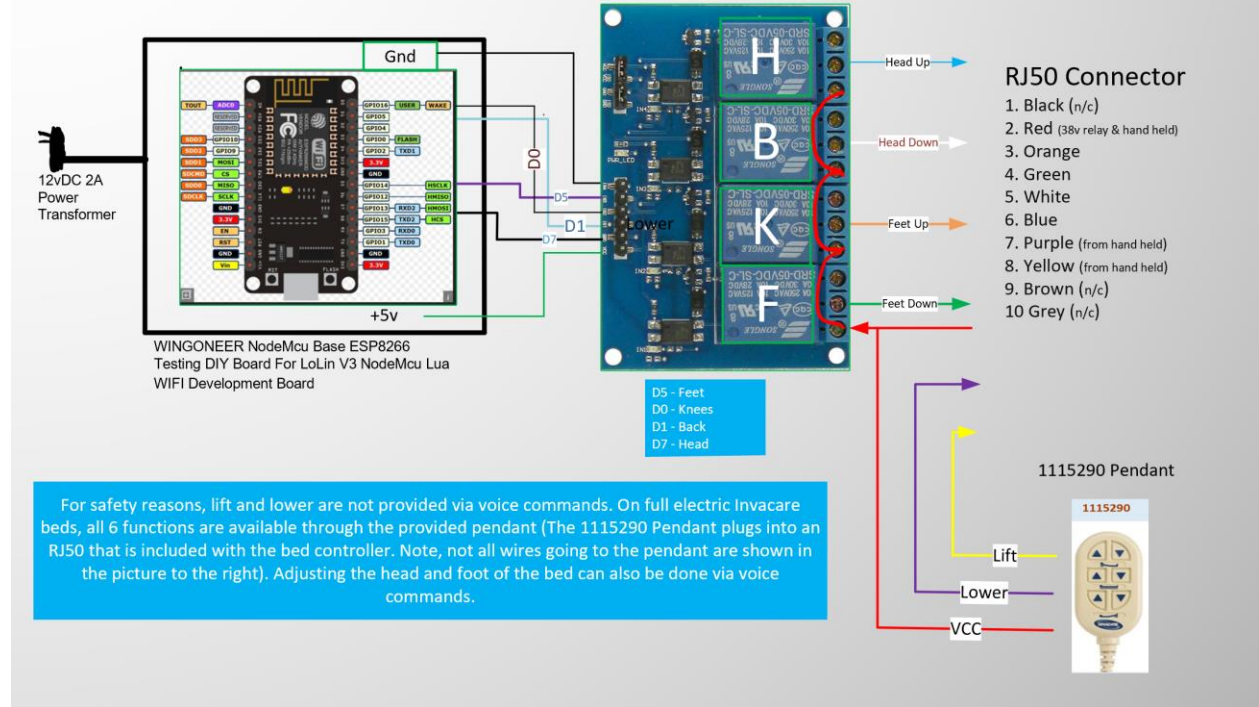

Resources

[Amazon Echo](#)

[Alexa Support](#) (Contact Support via the Amazon Alexa app - can have them call your number)

[Google Home getting started](#)

[Google Home Help Forum](#)

[Google Home Support](#) Phone number for Google Home hardware support = 855-971-9121 (24/7 days a week)

[Logitech Harmony Knowledge Base](#)

[Logitech Harmony Support](#) Phone # for Support = 866-601-5644 (M-F 8am to 6pm PST)

[Lifx](#)

[Wemo Support](#) Phone number for Support = 1-844-745-wemo (9366)