

Saeed Rahni Project – Detailed view (v1)

By Bill Weis

Requirements:

1. Be able to use voice to control his TV
2. Be able to use voice to place and receive phone calls
3. Be able to use voice to control his adjustable Drive Semi-Electric bed

Solution – High Level:

1. We provided an Amazon Fire TV Cube so Saeed could control his TV
2. Saeed is able to place phone calls using the Amazon Echo Dot. We also provided an Amazon Connect to make it possible for Saeed to answer incoming phone calls.
3. We designed a voice activated bed controller that allows Saeed to control his Drive semi-electric bed.

Details of the Solution

1 – Voice Control his TV – Saeed wanted to be able to watch internet-based entertainment on Netflix and YouTube, as well as watch the Over-The-Air Antenna TV channels. We installed an Amazon Fire TV Cube. We had some challenges getting the Antenna based channels working but the firmware update seemed to resolve that.

2 – Be able to use voice to place and receive phone calls – Saeed can now place phone calls using the Alexa Echo dot. We provided an Amazon Echo Connect to allow Saeed to answer incoming phone calls over the land line.

3 – Be able to use voice commands to control his Semi-electric Drive bed – Saeed has a Drive Delta 1000 bed with a hard wired remote. He wanted to be able to use voice to raise and lower the head/foot of the bed. We provided a voice activated controller along with several voice commands that run for different durations of time for the head and foot of the bed. Custom commands were then created to Saeed's liking. Our voice activated controller plugs into the bed in place of the standard hand control (15030HC-G).

To extend the life of the relay contacts, we soldered Schottky SR2010 flyback diodes on the relay board.

Here is a visio diagram of the bed controller

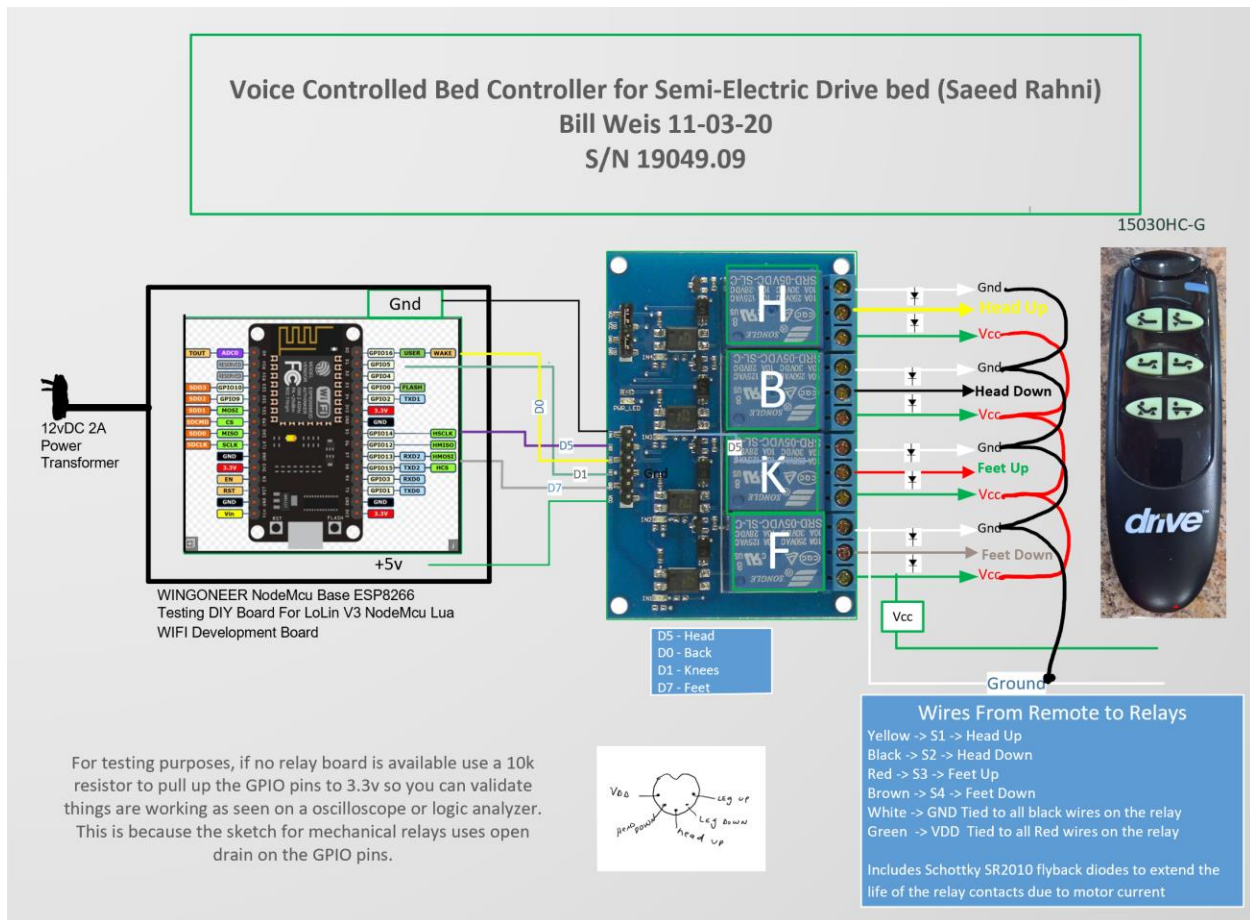

Resources

[Amazon Echo](#)

[Alexa Support](#) (Contact Support via the Amazon Alexa app - can have them call your number)

[Google Home getting started](#)

[Google Home Help Forum](#)

[Google Home Support](#) Phone number for Google Home hardware support = 855-971-9121 (24/7 days a week)

[Logitech Harmony Knowledge Base](#)

[Logitech Harmony Support](#) Phone # for Support = 866-601-5644 (M-F 8am to 6pm PST)

[Lifx](#)

[Wemo Support](#) Phone number for Support = 1-844-745-wemo (9366)